

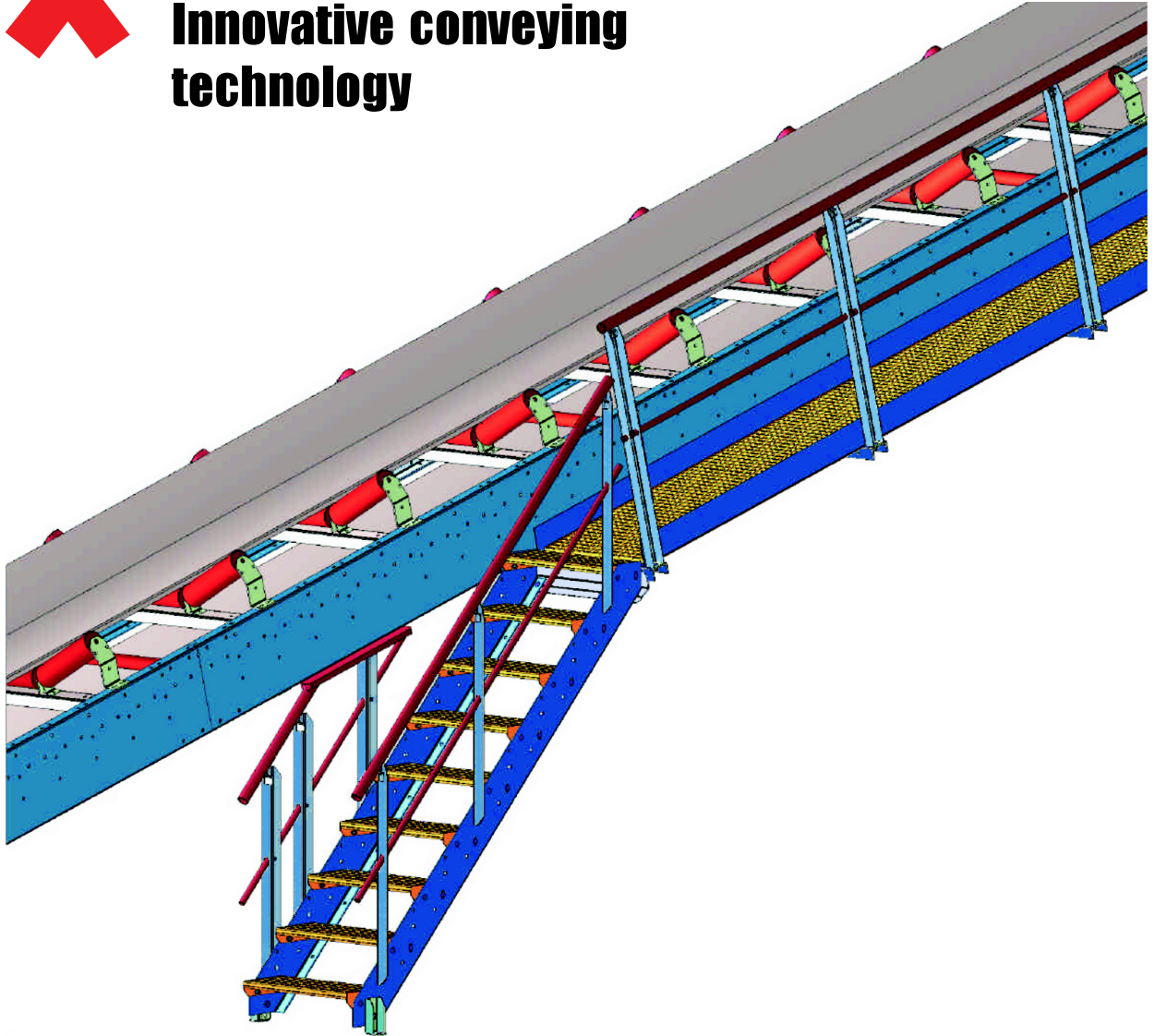

Gangways, stairs, ladders

Innovative conveying
technology



Compatible modular technology

* for VHV Belt Conveyors
Capable of being bolted to any VHV conveyor





Gangways, stairs, ladders

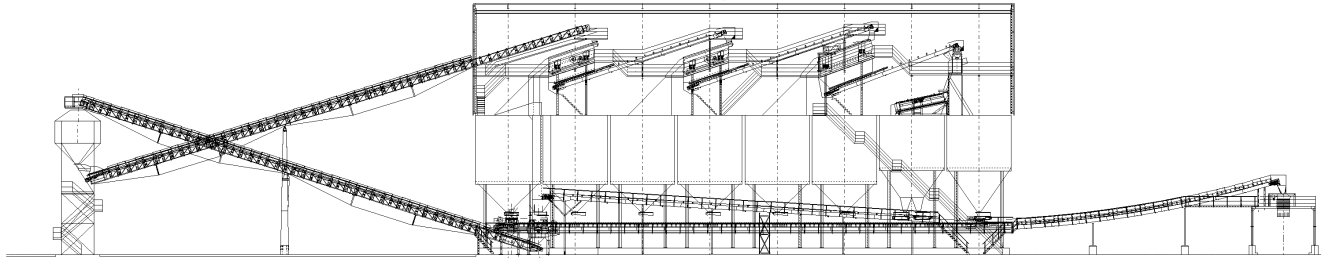

Maintenance gangways can be bolted to all VHV belt conveying systems. For all conveyors greater than 1000 mm in width, it is recommended to have a gangway on each side of the conveyor. The width of the gangways are 600 mm, 800 mm and 1000 mm. A non-skid surface is available based upon the end users' need. These systems are built with galvanized steel. They are designed to meet all safety regulations. Ascension ladders are supplied with a safety cage as dictated by safety requirements.

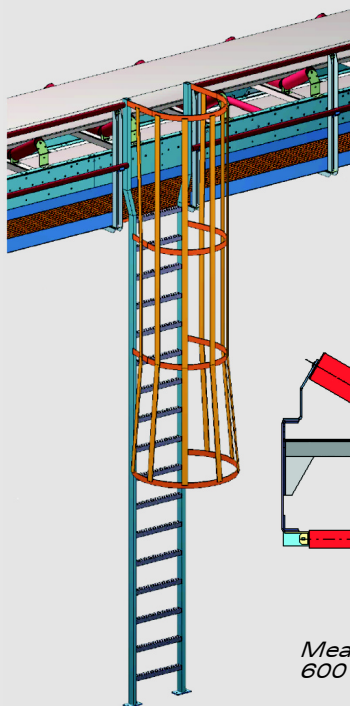

Ascension ladder with a safety cage

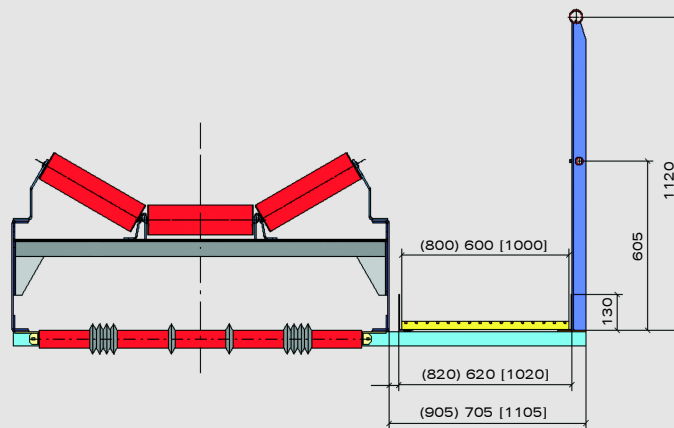

Measurements of gangways with a width of 600 mm, 800 mm and 1000 mm



VHV double belt vertical conveyor with a stairs tower

